



Focus on the Insulation System: Mitigation of corrosion under insulation

FESI document 10



FEDERATION EUROPEENNE DES SYNDICATS D'ENTREPRISES D'ISOLATION
EUROPEAN FEDERATION OF ASSOCIATIONS OF INSULATION CONTRACTORS

March 2015

www.fesi.eu

FESI Thermal technical document 10:

Focus on the insulation system

Mitigation of corrosion under insulation

Summary

- Executive Summary 3
- 1. Introduction..... 4
- 2. Under insulation corrosion 5
- 3. Considerations for mechanical designer 6
- 4. Considerations for contractor/insulation designer 7
- 5. Maintenance considerations for operator 8
- 6. Guidance for practical insulation work 9
 - 6.1 Introduction 9
 - 6.2 Hot insulation – Pipelines 9
 - 6.3 Hot insulation – Vessels, columns and tanks..... 14
 - 6.4 Cold insulation – Pipelines 14
 - 6.5 Cold insulation – Vessels, columns and tanks 15
- 7. Further information 16
- Appendix A Corrosion Under Insulation 17
 - A.1 General 17
- Appendix B More considerations for mechanical designer 18
 - B.1 Introduction 18
 - B.2 Anti-corrosion coatings..... 18
 - B.3 Protection against the ingress of moisture 18
- Appendix C More considerations for contractor/insulation designer 20
 - C.1 Standards..... 20
 - C.1.1 General 20
 - C.1.2 Insulation..... 20
 - C.2 Claddings 21
 - C.2.1 Non-metallic cladding 21
- Appendix D More maintenance considerations for operator 22
 - D.1 Introduction 22
 - D.2 What the operator should look for..... 22
 - D.3 Where to look..... 22
 - D.4 Inspection techniques..... 22

Executive Summary

- Corrosion is not caused by insulation but by ingress of aerated water.
- Corrosive materials can come from internal contaminants or external spills, marine or aggressive chemical environment.
- Corrosion can occur under all types of insulation materials.
- Carbon steel is considered at risk in the range +4°C to +175°C and stainless steel in the range +50°C to +175°C.
- Plant and equipment operating at dual temperatures, undergoing regular shutdown or in a discontinuous process are particularly at risk.
- By its very nature, "corrosion under insulation" tends to go undetected unless there is equipment failure or the insulation system is opened up.
- Once water has penetrated the cladding and entered the insulation, corrosion will begin and will continue.
- To minimise the risk of this occurring, the whole lifecycle of the insulation system must be examined.
- In this paper, guidance is given on the items that should be considered at the design stage, the installation techniques that should be employed to minimise the risk and then the completed insulation system should be routinely inspected and maintained.
- Deciding not to insulate is not the solution as this decision will lead to unacceptable heat losses and gas emissions.

1. Introduction

Who can influence under insulation corrosion?

The immediate answer is often the insulator!

But what about:

- The financier?
- The specifier?
- The equipment / piping designer?
- The construction planner?
- The insulation inspector?
- The maintenance manager?
- The plant operators?
- The outage teams?
- Other trades working on site?

What part do they all play?

To prevent under insulation corrosion the complete life-cycle of the insulation system must be considered.

What are the influencing factors?

This paper sets out to address the prevention of corrosion under insulation at the key points in the insulation system life-cycle:

- Design
- Installation
- Inspection and maintenance.

2. Under insulation corrosion

By its very nature, "corrosion under insulation" tends to go undetected unless the insulation system is opened up. Once water and/or other chemical agents have penetrated the cladding and entered the insulation, corrosion will begin and will continue. In this paper, guidance is given on the items that should be considered at the design stage and the installation techniques that should be employed to minimise the risk.

Some significant aspects of metal corrosion have been dealt with already, in FESI Document 09 "Principles of metal corrosion". All recommendations given here concerning anti-corrosion treatments of metals used in industry apply also in the context of "prevention of corrosion under insulation".

The presence of water is essential for the onset of corrosion: If there is no moisture and/or no water, then there is no corrosion. So the prevention of water penetrating the insulation system is paramount.

Water can penetrate insulation systems in three different ways:

- Gaps or openings in the cladding can allow the ingress of rain, spilt water or other liquids.
- Water vapour can get inside the insulation system due to air movement through gaps or openings in the cladding.
- Water vapour can penetrate the insulation system by water vapour diffusion.

Corrosive contaminants enter the insulation system via the ingress of rain, spilt water and the penetration through gaps or openings in the cladding, by water vapour as a result of air movement.

- The risk of water penetration as a result of air movement is most likely with cold insulation where the saturated vapour pressure inside the insulation system is lower due to the lower temperature.
- It should also be noted that hot insulation systems are occasionally "cold" when they are off load, the temperature inside the insulation system may fall below the ambient temperature.

There is further consideration of this topic in Appendix A.



Effects of water penetration at vessel stiffener

3. Considerations for mechanical designer

Summary

- Insulation must **not** be an afterthought. If the insulation thickness is not known, and the need for it to be known at the stage when the pipework, vessels and equipment are being designed is not realised then the integrity of the subsequent insulation system is likely to be compromised. The following must be considered:
 - The insulation system at equipment / plant design stage:
 - The philosophy of surface protection of the equipment / plant / pipework.
 - Pipe supports that allow effective cladding/covering sealing and for the continuity of the insulation system and vapour barrier.
 - Avoidance of upward facing penetrations of the insulation system. These are difficult / impossible to seal for the whole plant lifetime.
 - The requirement for insulation and cladding fixing points at equipment build stage.
 - Ensure that pipe stubs, manways etc. are long enough to allow the full insulation thickness and are provided with a means of terminating the insulation cladding or covering.
- High Quality Specification is required – with awareness of required insulation thicknesses to ensure sufficient space is allowed.
- Selection of insulations systems must take into account the service temperature, climate and location.

There is a detailed consideration in Appendix B.



The result of the thickness of insulation not being considered at the mechanical design stage.

4. Considerations for contractor/insulation designer

Summary

- Do not focus on the insulation material alone, but consider the whole insulation system (insulation materials, supports, claddings/coverings and fixings) and how the system is installed.
- Quality of planning, storage, installation, inspection and maintenance.
- Effective Client liaison.
- The insulator should be an appropriately qualified and accredited installer.
- Allow means for water to get out via drain holes or tubes.
- Effective stage inspection and quality control system.
- Effective Client TQ (technical query) system which prioritises effective insulation
- Avoid the need for insulation to be walked on.
- Identification of areas where insulation systems must be robust enough to withstand some foot traffic or other mechanical attrition in areas such as on tank roofs or pipe crossing points.

The general rules for the execution of insulation work on industrial installations can be found in:

- FESI document 2: FESI guide to good insulation practice;
- FESI document 3: Code of Practice for carrying out thermal insulation work at above and below ambient temperature in the temperature range -80°C to $+850^{\circ}\text{C}$;
- And in national standards.

There is a detailed consideration in Appendix C.



The extreme result of water penetration, product escapes!

5. Maintenance considerations for operator

Summary

- It is essential that Clients' operations and maintenance staff understand that insulation systems' effective lifetime depends on regular inspection and maintenance.
- Education of the other trades on site is required to report insulation damage (in the same way that they are expected to report accidents and other incidents.)
- Quick response to Client's inspection is needed to decide whether inspection of the surface below the damaged insulation is required.
- Understanding of the need for quick response by maintenance team to repair reported damage is essential.
- Education of Clients' shutdown teams should be included in induction to explain importance that the insulation systems are not damaged and that damage is reported immediately.
- Regular routine inspection of the insulation system must take place with immediate response and repair.

There is a detailed consideration in Appendix D.



External application - The result of foot traffic and no inspection and maintenance!

6. Guidance for practical insulation work

6.1 Introduction

There are a number of specific points that should be considered during the installation and application of the insulation system.

6.2 Hot insulation – Pipelines

1. On vertical end plates do not use standing seams.
2. For cladding joints on vertical pipes or vessels, the overlaps should always be installed so as to shed water (weather-wise – roof tile method).
3. Spindle protrusion on valve boxes are a likely point of liquid ingress. Special care is needed for sealing. Avoid positioning spindles vertically upwards wherever possible.
4. Longitudinal cladding seams should be installed on the side away from the prevailing weather, wherever possible. The joint should be weather-wise and more than 90° from the vertical.

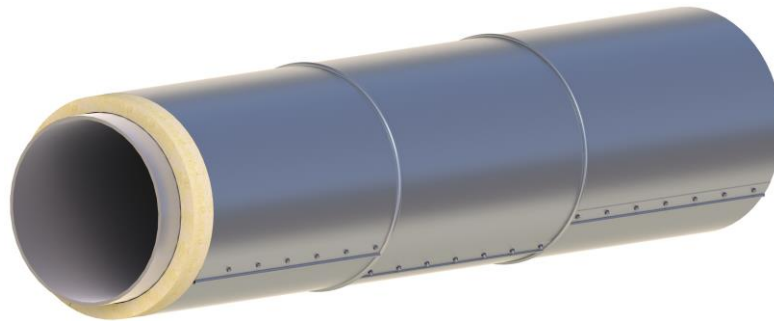

Horizontal pipe with screws



5. Where electrical or steam tracing penetrates the pipe work cladding, the position should be away from prevailing weather and more than 90° from the vertical.
6. On high service temperature applications, where expansion joints are required, they should be installed to prevent seams opening up. This will also apply to long horizontal pipes between two fixed points.

7. The overlaps on the circumferential and longitudinal seams should be sufficient.

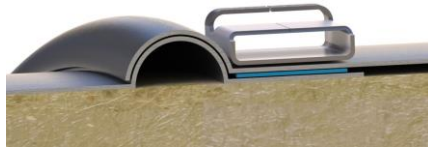

Male to male swage with sealer strip in metal overlap

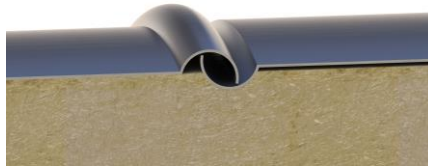

Male to female swage for bends

8. Pipe supports are a likely source of liquid ingress. Insulation and cladding should be continuous through the pipe support.

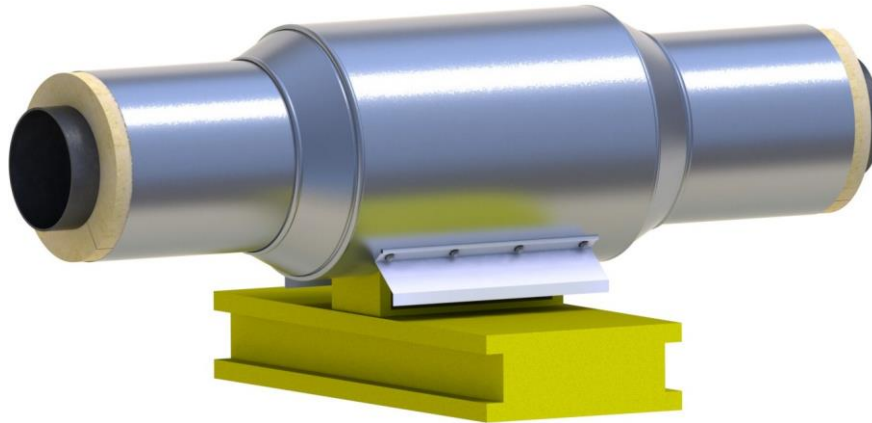

Pipe support with watershed insert

9. Drain holes should be installed at the low points in all claddings.

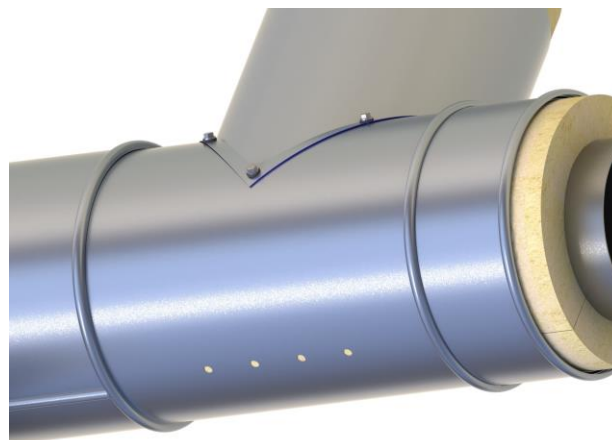

Drain holes at low point of cladding

10. At water shed, cover should be installed above all pipe hangers.

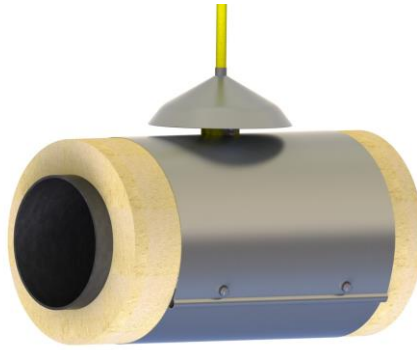

Pipe support with water deflector

11. Wherever possible, a tee piece connection with the pipe cladding should be installed with the joint weather-wise.

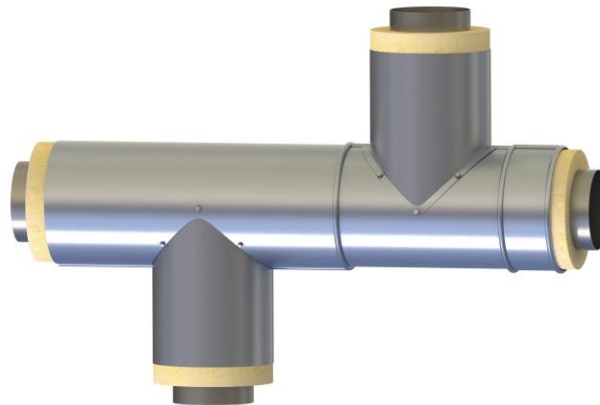

Tee pieces above and below pipe showing water shed

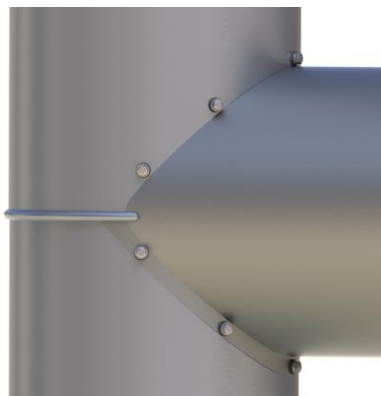

Vertical tee showing different watershed joints on top and bottom halves

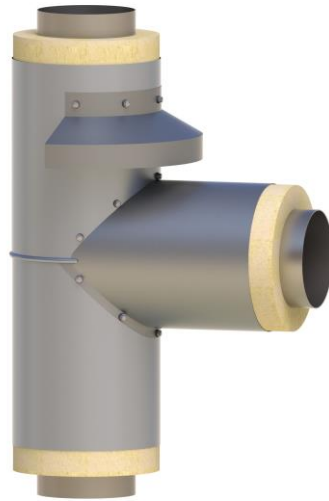

Vertical tee piece showing additional water deflector



Elbow with conical end cap

12. Check on small ball or plug valves that there is an extended spindle to allow the full thickness of insulation.
13. Formation of a ventilated air space between cladding and insulation material for installations in the open, by means of drain holes.

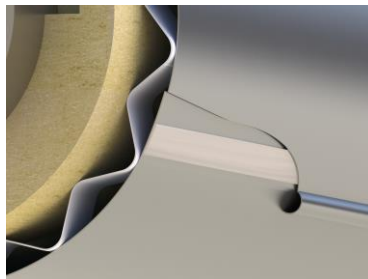

*Air gap between insulation and cladding
(cut away to show sealer strip)*

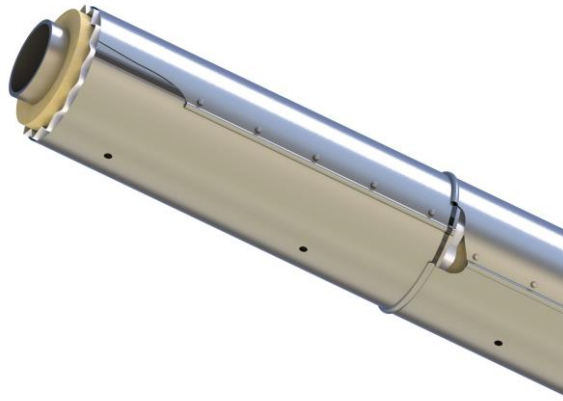

Insulated pipe with air gap between cladding and insulation and drain holes

14. Formation of a ventilated air space between insulation and pipe by means of pipe drains and drain holes.

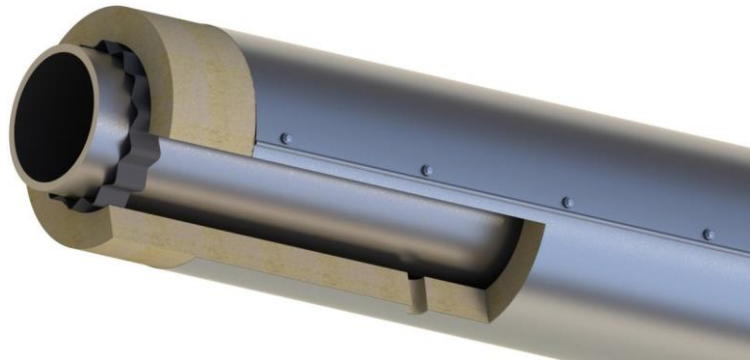

Non-contact insulation with pipe

15. Where insulation terminates below a flange then conical termination cladding piece should be fitted.



Sealing cone for vertical pipe at flange

16. For protrusions through insulation and cladding, if an engineered solution is not possible then use a sealing compound.

6.3 Hot insulation – Vessels, columns and tanks

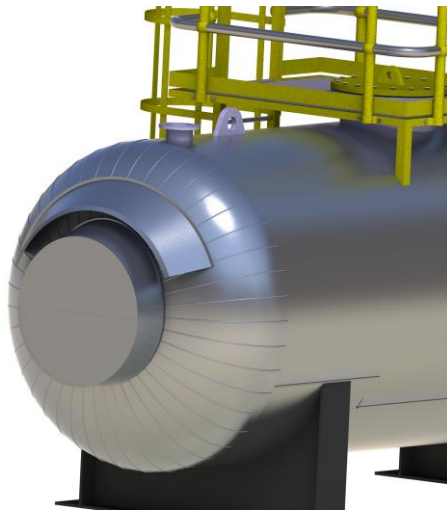

Dome end of vessel showing water deflector

1. Ensure there is sufficient distance between the flange face and vessel wall for insulation thickness and bolt length.
2. Ensure the length of name plates, thermocouples, ladder supports and other projecting items, project sufficiently to allow full insulation.
3. Establish the termination points for anchoring the bands on the tops of columns and vessels.
4. Ensure that the top plates of vertical manholes always slope.
5. Ensure that the cladding on vacuum rings is always fitted weather-wise.
6. Ensure that insulation cladding around projecting vessel supports is installed so as to shed liquid.
7. Preferably make the vessel top insulation thicker so that the lifting lugs are enclosed by the insulation so as to shed liquid.
8. Cladding of vertical connections should always be installed with joints weather-wise so as to shed liquid.
9. Leave tank bottom edge free of insulation for inspection and install an eaves flashing / rain deflector when tank roof is not insulated.
10. Ensure that all tank roof cladding is fitted weather-wise.
11. Check that the kicking plate on the tank roof handrail allows sufficient clearance for the full insulation thickness to be applied.
12. Use clips for insulation support rings than flat steel angle to support the insulation and cladding.

6.4 Cold insulation – Pipelines

1. Self-tapping screws with EPDM coated steel discs or stainless steel bands should be used to close the seams of the cladding.
2. Careful consideration must be given to the installation of contraction joints.
3. Where insulation is terminated, the end of the insulation should be covered with an extra layer of mastic rather than metal capping piece / end plate.

4. Check the valve of flange box connection onto the pipeline cladding.
5. The connection between the pipe support material and the insulation should be a stepped joint. The vapour barrier material and the cladding material should be incorporated into the pipe support under the clamp. This will allow a continuous vapour barrier and cladding system to be maintained.

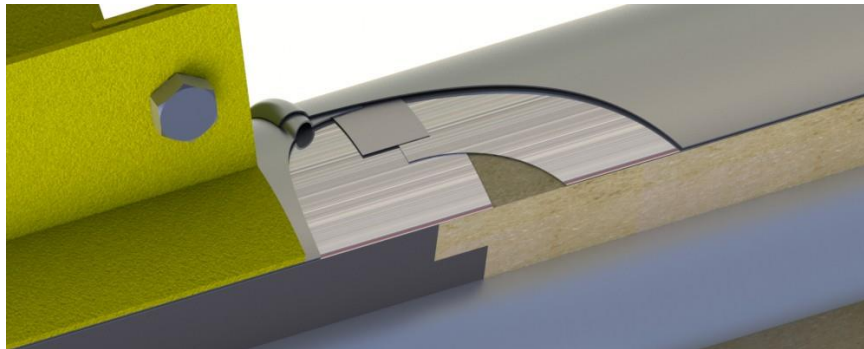

The detail at a pipe support showing how an appropriate pipe support design will allow complete integration of the insulation system of insulation, vapour barrier and cladding to maintain continuity of all three of them.

6. Bands should be used on elbows to close the seams.
7. Drain holes should be installed at every low point.
8. Wherever possible, valve spindle protrusions should be better insulated.
9. Supports at fixed points should be designed without thermal bridges.

6.5 Cold insulation – Vessels, columns and tanks

1. On vertical vessels and lines, S clips should be used to support the cladding.
2. Support bands with clips so that they cannot slip down.
3. Insulate skirts of columns down three times the insulation thickness.
4. Install a thermal break between support and vessels.
5. The steel on which the vessel is supported should be insulated.
6. Where possible, prefabricated head segments should be used on vessel and column ends and tops.
7. Use of dome-shaped covers to allow for the rain-tight connection of e.g. exiting non-insulated pipes or round supports on walking gantries.
8. At horizontal surfaces of installation components the cladding sheets shall have a minimum slope of 3 %.
9. Insulated pipes should preferably be fastened with external supports.
10. Formation of an air space between cladding and insulation material for installations in the open, by means of drain holes.
11. Stiffening of the roof sheets of tanks, ducts and containers through stiffening folds into the insulation material or through standing seams with caps.

12. Insulate the saddles of horizontal vessels along three times the insulation thickness.
13. Ensure that the vapour barrier is free of pin holes and has an even thickness.
14. Check that there are enough supports for the insulation and that these supports are not too long.

7. Further information

More detailed information or advice can be obtained from the insulation contracting industry association in your country via the FESI website www.fesi.eu.

Appendix A Corrosion Under Insulation

A.1 General

The ingress of moisture into the insulation system and the consequential concentration of chlorides in the insulation enhance the corrosion of insulated parts of the installation. Moisture may even lead to the concentration of corrosive substances from the atmosphere in the insulation system. Therefore, consideration must be given to how corrosion of the object can be prevented through appropriate anti-corrosion applications and/or design of the insulation system.

With the intake of moisture, the insulating effect of the insulation material decreases. A rough estimate, supported by research data, suggests that a 1 vol.-% of water in the insulation material leads to an appropriate 4% increase in the thermal conductivity. A water concentration of 5 vol.-% of the overall insulation material's volume increases the λ value by 20%. This renders the insulation ineffective.

Also, the moisture absorption can lead to physical changes, e. g. frost heaving or mechanical damage. Water leads to the breakdown of some insulation materials, including such as microporous material, calcium silicate and mineral fibres.

Hydrophobic treatment of insulation materials does not protect against moisture concentration and the ingress of chloride ions. It only constitutes a temporary protection against the ingress of rain water during assembly of the insulation. It does not replace weather protection.

Chloride ions can cause stress-corrosion cracking in 300 series stainless austenitic steels. Insulation with mineral wool requires, for example in Germany, the use of AS-quality mineral wool according to AGI working document Q 135. In the UK, the use of aluminium foil applied to the surface of the object prior to insulation is required.

Practical experience has shown that the presence of moisture in insulation systems must be taken into consideration. The absorption of moisture normally occurs in three different ways:

1. Ingress of water (rain or spilt water).
This can be caused by mistakes in design and construction, e. g. wrongly positioned branches and fittings, missing flashings / rain deflectors and damage to the cladding allowing the penetration of water. Imperfect installation of the insulation may be an additional reason.
2. Condensation formed in the insulation caused by water vapour diffusion.
This moisture mainly occurs when parts of the installation are operating below ambient temperature.
3. Formation of condensation in the insulation caused by air exchange with the ambient atmosphere.
This mostly occurs when installations are operated in interrupted service, but also with installations outside where the ambient temperature influences are consistently changing. The reduction in ambient temperature, which can also be caused by rain or thermal radiation at night, results in a lower saturated vapour pressure in the insulation, resulting in moisture being transported into the insulation with the ingress of ambient air. This leads to large amounts of water vapour being transported into the insulation system in short periods. Warming-up of the insulation system, for example as the installation is switched on again, causes an increase in vapour pressure leading to a reversal of the air movement, however, the moisture generally remains in the insulation as condensation.

Appendix B More considerations for mechanical designer

B.1 Introduction

Corrosion under insulation costs the chemical and petrochemical industries a large amount of money.

The designers of pipe work, vessels, tanks and associated equipment should be encouraged to consider the effective installation of "liquid proof" insulation systems at the design stage.

This will require installation of a mechanical means of termination of the insulation cladding. As a result, the type and thickness of insulation must have been considered at the same time as the fabrication of the objects to be insulated.

Specific items that should be considered include:

- Ensuring there is sufficient clearance between all plant items and walls to allow the full insulation thickness, free convection and cladding to be correctly installed.
- Providing the means for the cladding to run through pipe supports or hangers without interruption.
- Providing termination flanges, allowing full insulation thickness on walking ways, pipe stubs, walkway supports and other penetrations of the insulation cladding to enable cladding to be mechanically fixed. Designers should be reminded that simple cladding cut outs, patches and sealants will not normally withstand weathering, foot traffic and the rigours of mechanical maintenance.
- Where possible, valves should be installed with the spindles horizontal or below in order to minimise the risk of liquid ingress into insulated valve boxes around the spindle.
- Protect all surfaces, within the CUI temperature range, that will be insulated, with a protective paint system or foil.

All recommendations given in this document concerning anti-corrosion treatments of metals used in industry apply also in the context of "prevention of corrosion under insulation.

B.2 Anti-corrosion coatings

There is information in FESI Document 09 "Principles of metal corrosion". Examples of tested anti-corrosion systems are given in AGI working document Q 151 and Annex A 18 and A 19 and the CINI book, chapter 7. The type of paint must be agreed between client and contractor in each individual case.

B.3 Protection against the ingress of moisture

Before the insulation of an object is designed, it should be established whether or not it is likely to be exposed to rain and/or spilt water. This consideration and the operating temperature will determine whether sealing discs should be welded to parts of the object or whether flashings / rain deflectors should be used as part of the cladding.

Sealing collars must be fixed to all vessels and tanks that are to be insulated.

Objects in the open and in buildings, where they are subject to spilt water, must have sealing discs to all protrusions penetrating through the cladding.

It is recommended that the sealing discs and sealing collars as well as those parts of the installation, which are not insulated, are made of stainless austenitic steel. If made of ferritic steel, all surfaces must be coated prior to the application of the insulation. Inside buildings, this provision applies only to cold insulations.

The sealing of flashings / rain deflectors with sealing compounds is normally the responsibility of the insulation contractor.

The decision as to where welded sealing discs and collars shall be used, is normally the responsibility of the insulation designer, but should involve the insulation company.

The minimum thickness of sealing discs for vessels is 4 mm, for pipes 2 mm. The welding must not cause deformation.

Appendix C More considerations for contractor/insulation designer

C.1 Standards

C.1.1 General

The following preconditions should be incorporated into the quality control system to allow for the professional insulation of the object:

- Ensure that the appropriate insulation is used in the right places.
- Ensure the use of the correct cladding materials in places where they can give the best protection.
- Use the correct material application specifications and check the details so that it is known what to expect.
- Be aware that extra precautions will be needed to prevent water ingress where the installation is outside or only covered by a roof.
- Final check of corrosion-protection system.
- Corrosion-protection works on the object are finished according to the specification.
- Minimum distances have been maintained.
- A final check that there is sufficient space for the insulation (insulation layer thickness plus adequate installation space).
- Objects that will penetrate the insulation should be in place and properly protected.
- Appropriate sealing collars and sealing discs are welded to the object.
- Nozzles are of sufficient length that their flanges are outside of the cladding and with enough bolt clearance that they can be opened and closed without impediment.
- Supports are fitted so that insulation materials, vapour barriers and claddings can be attached correctly.
- The insulation can be applied without obstruction, e. g. by scaffolds.

C.1.2 Insulation

Insulation systems and insulation materials are selected to meet the particular technical requirements and the physical and other prevailing conditions (as described in previous FESI documents).

Selection should also consider factors that could affect the risk of under insulation corrosion such as location, space available, risk of foot traffic and chemical aggressiveness of the atmosphere.

C.2 Claddings

The cladding is a mechanical protection and/or protection against the weather. It plays a decisive part in the water protection of the insulant and thereby in the prevention of corrosion in the entire system.

Claddings are required where external influences might reduce the properties of the insulation material.

The appropriate cladding should be chosen with due consideration of:

- Location;
- Environment;
- Galvanic potential between the cladding and pipework/equipment material.

Claddings must not damage the vapour barrier. Provisions must be made to prevent screws or rivets from damaging the vapour barrier. The use of mineral wool "sacrificial layers" or like materials as a water vapour barrier protection is not advised.

C.2.1 Non-metallic cladding

A non-metallic cladding material can be considered an option, particularly where there may be:

- complexity of the equipment, i. e. with many penetrations such as walkway supports, nozzles, man-ways, thermocouples etc and particularly if they are upward facing. It may also be due to the result of foot traffic and mechanical damage, particularly in high access areas;
- aggressive chemical environment;
- a need to avoid galvanic corrosion.

The materials that can be considered, where mechanical damage is a significant problem, are:

- chloroprene rubber sheet;
- UV-cured glass-reinforced plastic (GRP) sheet;
- polymer backed multi-laminate sheet.

There are other acrylic based coatings that will provide an effective weather-shield where mechanical damage is not an issue.

By their nature, some of these materials are seamless as they are chemically bonded to themselves. They can be easily repaired by cutting out the damaged area and bonding a patch of the material into place. The manufacturer should be consulted to establish the maximum service temperature limit of the material.

Appendix D More maintenance considerations for operator

D.1 Introduction

All insulation systems should be regularly inspected for damage to the cladding and for "points of weakness" that could eventually allow water into the insulation system. The results and dates of these inspections should be recorded. Damaged cladding on outdoor installations should be rectified immediately to prevent water penetration of the insulation system, which would reduce the insulation's properties and initiate corrosion under the insulation. Damaged vapour barriers must be sealed as soon as possible or else water vapour will enter the insulation through the damaged area. In areas where the cladding is damaged, the insulation should be removed to allow inspection of the substrate for corrosion. As part of the inspection programme, "high risk" areas for corrosion should have the insulation system removed on a regular basis to detect possible corrosion under insulation as early as possible to reduce maintenance cost. Consideration should be given to preparing inspection points that will cause minimum disruption to the cladding and therefore make the resealing of the system most effective.

D.2 What the operator should look for

- Production processes and environments with the potential to cause harm;
- Construction features of the plant with potential to allow water penetration and corrosion;
- Damage to the cladding that could allow water to penetrate the insulation system;
- Observation of "rust water" or deposits of rust;
- Ice which could be due to vapour barrier damage;
- Use of thermography can indicate where further investigation is needed.

D.3 Where to look

- Carbon steel piping systems operating between $-4\text{ }^{\circ}\text{C}$ and $+175\text{ }^{\circ}\text{C}$.
- In areas around supports, hangers, ladders and other items penetrating the cladding.
- In systems with dual service requirements, i. e. service temperatures above and below ambient, and with frequent/regular shutdowns.
- In areas exposed to spray from cooling towers, steam vents or deluge water.
- In steam traced systems.
- Halide stress corrosion cracking could occur in systems made from stainless austenitic steel operating between $+50\text{ }^{\circ}\text{C}$ and $+175\text{ }^{\circ}\text{C}$.
- Systems that vibrate will often damage the cladding by loosening or shearing the cladding fixings.

D.4 Inspection techniques

- Periodic systematic visual inspection of the insulated system.
- The most effective method is to remove the insulation in representative areas.
- Indirect methods, such as thermal imaging, can also be used to track possible under-insulation corrosion.

The information contained in this document is considered by us to be good practice and industry guidance. The Guidance is provided by a commission of FESI (www.fesi.eu), and is considered to be correct at the date of publication. Whilst we are confident the information contained within it is up to date and accurate, it is a reference document only. It is your responsibility to ensure your knowledge of the matters discussed in the Guidance is kept up to date.

The Guidance is intended to be used for general purposes only and is not intended to take precedence over appropriate national and international standards, guidelines or laws (where applicable). The Guidance is not intended to replace detailed calculations and assessments of prevailing physical conditions in complicated building assignments.

The Guidance does not constitute professional advice and specific queries should be referred to qualified professionals. Any reliance placed on the Guidance without seeking such advice is strictly at your own risk. We make no representations or warranties of any kind, express or implied, about the completeness, accuracy, reliability or suitability of the Guidance.

The Guidance in its original form is written in English. We accept no responsibility for any inaccuracies contained in any translation of the Guidance in languages other than English.

The Guidance is provided free of charge and as such in no event will we be liable for any loss or damage including, without limitation, indirect or consequential loss or damage, or any loss or damage whatsoever arising from any reliance placed on the Guidance. None of these exclusions or limitations, however, are intended to limit any rights which may not be excluded, nor to exclude or limit liability to you for death or personal injury resulting from our negligence or for other liability which we cannot exclude or limit by law.