



Kooltherm™ Pipe Insulation Quick Guide

HVAC & Building Services Insulation System



Contents

Introduction	3
Kooltherm™ Pipe Insulation	4
Features & Benefits	6
Recommended Thickness	8
Kooltherm™ Pipe Supports	12
Kooltherm™ FireSleeves	14
Technical Data	16
Case Studies	17
Market Sectors	18

Introduction

Kingspan is a market leading manufacturer of premium performance pipe and duct insulation products and systems.

Kingspan premium performance insulation products are the thinnest and most efficient products commonly available for the insulation of pipework and ductwork in building services / HVAC, process and petrochemical applications and refrigeration services.

Products are supported by the complementary Pipeline Technical Advisory Service, providing guidance for designers, specifiers, consulting and mechanical engineers, mechanical and electrical M&E contractors, thermal insulation contractors' as well as building services and facilities managers.



Building Information Modelling (BIM)

Kooltherm™ Pipe Insulation is now available as a freely downloadable BIM file from the BIM Store and from the Kingspan Insulation website and is available in the leading Revit format. For further information, please contact the Pipeline Technical Advisory Service.

Certification

Kooltherm™ Pipe Insulation and Kooltherm™ Insulated Pipe Supports are CE Marked in accordance with BS EN 14314.

The performance, application methods and factory production control of Kooltherm™ Pipe Insulation have been assessed and certified by KIWA N.V. Technical Assessment Body. The use of Kooltherm™ Pipe Insulation is covered by KIWA BDA Agreement certificate BAP 15-036/01/C.

The performance of Kooltherm™ Pipe Insulation has also been assessed by Local Authority Building Control and is covered by LABC Registered Detail RD certificate number EWW382. The use of Kooltherm™ Pipe Insulation is covered by LABC Warranty.

The Eurofins 'Indoor Air Comfort' product certification shows compliance of a product with low VOC (volatile organic chemical) emissions criteria.

Kooltherm™ Pipe Insulation has a best-in-class Eurofins Indoor Air Comfort Gold certificate which recognises the product as an outstanding material according to VOC Indoor Air Quality emissions standards across Europe, and compliance for both BREEAM and LEEDv4.



Kooltherm™ Pipe Insulation

Kooltherm™

HVAC & Building Services Pipe Insulation

Kooltherm™ Pipe Insulation comprises sections of Kooltherm™ Insulation faced with a factory-applied foil vapour barrier jacket autohesively bonded to the insulation core during manufacture.

Kooltherm™ Pipe Insulation is CE Marked in accordance with BS EN 14314.

Kooltherm™ Pipe Insulation is available in a range of thicknesses to suit different performance specifications and may be used on mild steel, stainless steel, carbon steel, copper, multiplex and plastic pipework in standard and non-standard pipe diameters.

Kooltherm™ Pipe Insulation is manufactured using state of the art continuous and cut from block technologies. Both methods feature the use of a unique bore coated liner / bore coating and minimise production wastage.

Kooltherm™ Pipe Insulation is supplied in 1 metre lengths and is available in a standard density of 37 kg/m³. Higher density pipe insulation sections and insulated pipe supports fabricated from 60 kg/m³, 80 kg/m³ and 120 Kg/m³ densities are also available.

Kooltherm™ Insulated Pipe Support Inserts

Kooltherm™ Insulated Pipe Support Inserts provide optimal load bearing capacity whilst offering protection against insulation compression. Designed for use in pipe supports, hanger brackets and clamps, they will support the compressive loads imposed by horizontal pipework carrying water or other liquids.

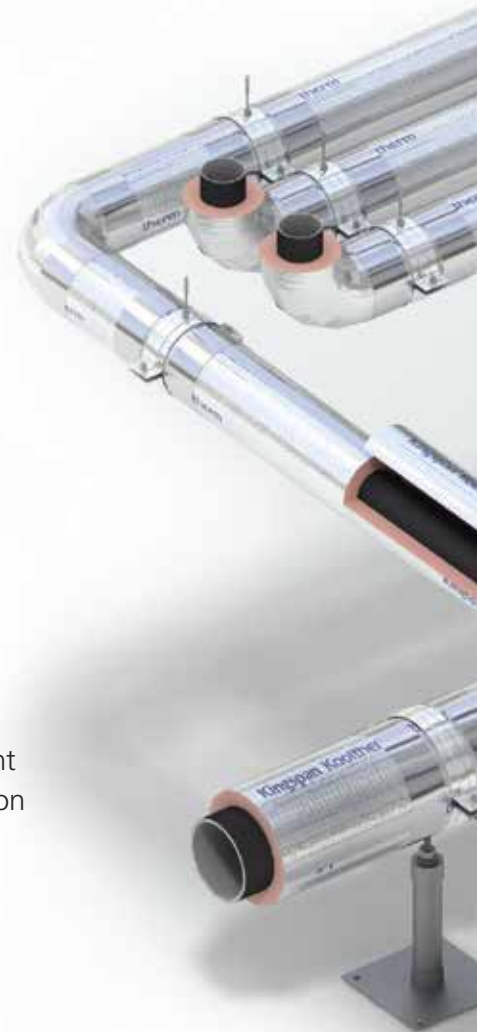



Vapour Barrier Jacket

All Kooltherm™ Pipe insulation products and systems are faced, as standard, with an extremely durable and protective low vapour permeability aluminium foil or theatre black vapour barrier jacket reinforced with a glass scrim.

The vapour barrier jacket is factory-applied to avoid onsite application, which carries the risk of vapour barrier damage and with it, a risk to the integrity of the system. This also reduces the labour cost for installation of the Kooltherm™ Pipe Insulation System.

A matching self-adhesive tape is used to complete the vapour barrier at joints and breaks.

Features & Benefits

Thermal Performance

With a 25 year aged thermal conductivity as low as 0.025 W/m·K (at 10°C mean), Kooltherm™ Pipe Insulation is the most thermally efficient insulation material commonly used. A low thermal conductivity allows specified thermal performance standards to be achieved with thinner insulation.

The superior thermal performance of Kooltherm™ Pipe Insulation derives mainly from its closed cell properties. Its closed cell structure has been optimised to resist heat transfer. The closed cells have a small solid to void volume ratio, are small and uniform in size, and their construction very fine with extremely thin walls and minimum point contacts (struts).

They are filled with a thermally efficient CFC/ HCFC-free blowing agent that has zero Ozone Depletion Potential (ODP) and low Global Warming Potential (GWP).

As a result of its closed cell, fibre free structure, Kooltherm™ Pipe Insulation is unaffected by air infiltration – problems that can be experienced with mineral fibre and which can reduce thermal performance.

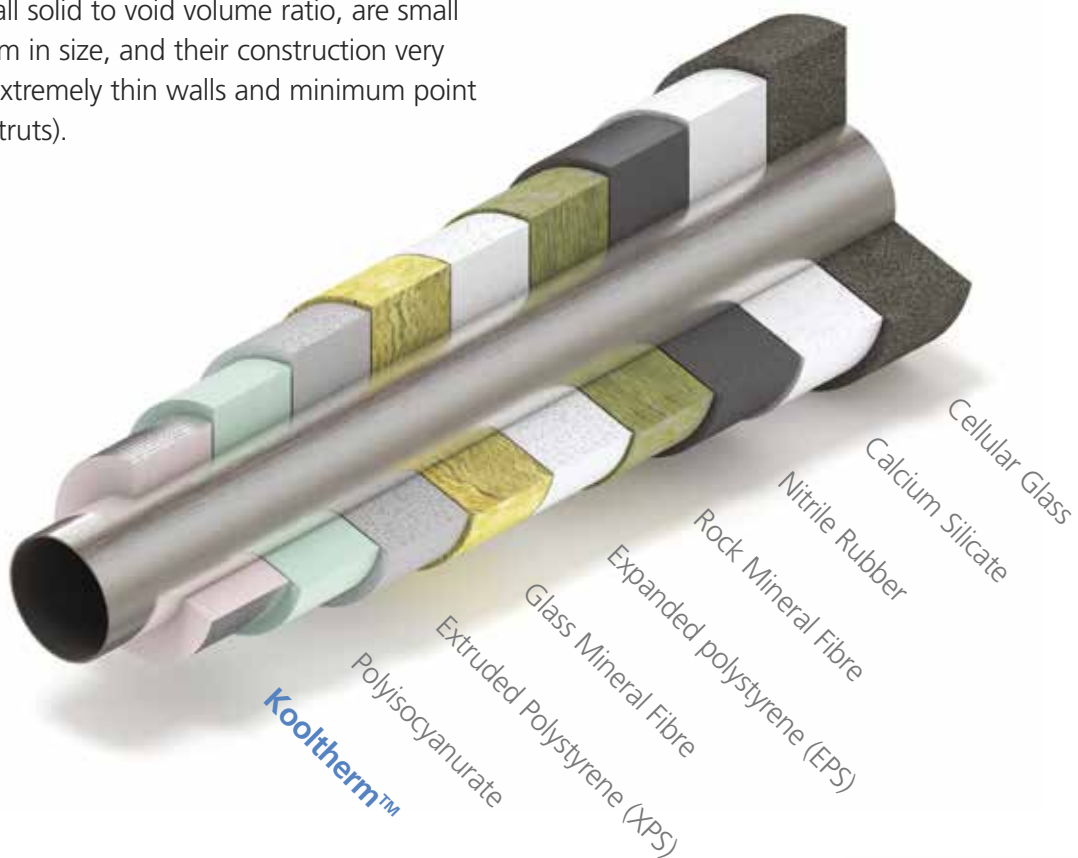

Moisture Resistance

Kooltherm™ Pipe Insulation has a 90% (or greater) closed cell structure. The risk of moisture absorption into the insulation is effectively eliminated as the factory-applied facing to Kooltherm™ Pipe Insulation products and systems provides a high performance vapour barrier jacket.



Fire

Kooltherm™ Pipe Insulation products and systems have a densely cross-linked structure that makes them difficult to ignite and when subjected to fire, the outer surface forms a strong carbonaceous layer that limits heat generation and retards further flame spread.

The excellent fire and smoke performance characteristics of Kooltherm™ Pipe Insulation products and systems clearly demonstrates their suitability for the designated application, with European Reaction to Fire performance of B_Ls1,d0.

Kooltherm™ Pipe Insulation is Approved per Approval Standard Class 4924.



Fire Test Classifications (Kooltherm™ Insulation)

Property	Test Method	Typical Result
Reaction to fire	EN 13501-1	B _L - s1, d0
Surface Burning Characteristics	ASTM E 84	Class A/1 (FSI 25/SD 50)
Fire propagation and flame spread		Class 0, in accordance with criteria set out in Approved Documents B for England & Wales

Environmental

Kooltherm™ Pipe Insulation can directly contribute towards the award of several credits under the previous and current versions of BREEAM.

The product holds a highest possible BRE Green Guide rating of A+ and is manufactured to a BS EN ISO 14001: 2004 scheme, qualifying for the Responsible Sourcing credit. In addition, Kingspan Industrial Insulation offers a 'zero landfill, take-back' scheme, using waste product collected from off-site manufacturers for recycling or energy recovery.



Manufactured to
BS EN ISO 9001: 2008
Certificate No. 935626/1



Manufactured to
BS EN ISO 9001: 2015
Certificate No. 388-2QMS
BS EN ISO 14001: 2004
Certificate No. 388-2EMS
BS OHSAS 18001: 2007
Certificate No. 388-2HS



Recommended Thickness

Insulation Thickness Table to Control Heat Loss: BS 5422:2009

Steel Pipe Size			Hot Water 60°C			Low Temperature Heating Water ≤95°C		
			Kooltherm™		max. heat loss	Kooltherm™		max. heat loss
NB (inches)	NB (mm)	OD (mm)	ε=0.05 silver	ε=0.9 black	(W/m)	ε=0.05 silver	ε=0.9 black	(W/m)
3/8	10	17.2	15	15	6.60	15	15	8.90
1/2	15	21.3	15	20	7.13	15	20	9.28
3/4	20	26.9	15	20	7.83	20	20	10.06
1	25	33.7	20	20	8.62	20	20	11.07
1 1/4	32	42.4	20	20	9.72	20	25	12.30
1 1/2	40	48.3	20	25	10.21	20	25	12.94
2	50	60.3	20	25	11.57	25	25	14.45
2 1/2	65	76.1	25	25	13.09	25	30	16.35
3	80	88.9	25	25	14.58	25	30	17.91
4	100	114.3	25	30	17.20	30	30	20.77
5	125	139.7	25	30	19.65	30	35	23.71
6	150	168.3	25	30	22.31	30	35	26.89
8	200	219.1	30	30	27.52	30	35	32.54
10	250	273.0	30	30	32.40	35	35	38.83

<i>Estimated Mean Temperature of Insulation:</i>	+50°C
<i>Ambient Air Temperature:</i>	+15°C
<i>Surface Emissivity ε (Outer Surface):</i>	0.05 / 0.9
<i>Assumed Thermal Conductivity (k-value) of Kooltherm™ 37kg/m³ Insulation:</i>	0.025 W/m·K

Table 1: Indicative Thickness (mm) of Insulation for Non-Domestic Hot Water (60°C) and Low Temperature Heating Service Areas (75°C) to Control Heat Loss.

(Based on Non-domestic Building Services Compliance Guide: 2013 Edition, Section 11; TIMSA HVAC Guide Sections 6.2.1 & 6.2.2; and BS 5422:2009 Tables 15 & 16).



Insulation Thickness Table to Control Heat Loss: ECA & Y50 Enhanced

Steel Pipe Size			Hot Water 60°C			Low Temperature Heating Water ≤95°C		
			Kooltherm™		max. heat loss	Kooltherm™		max. heat loss
NB (inches)	NB (mm)	OD (mm)	ε=0.05 silver	ε=0.9 black	(W/m)	ε=0.05 silver	ε=0.9 black	(W/m)
3/8	10	17.2	15	20	6.04	20	20	7.78
1/2	15	21.3	20	20	6.45	20	20	8.42
3/4	20	26.9	20	25	7.00	20	25	9.05
1	25	33.7	25	25	7.71	25	25	9.86
1 1/4	32	42.4	25	25	8.46	25	30	10.83
1 1/2	40	48.3	25	30	9.01	30	30	11.42
2	50	60.3	30	30	9.94	30	35	12.61
2 1/2	65	76.1	30	30	11.25	35	35	14.12
3	80	88.9	30	35	12.17	35	35	15.28
4	100	114.3	35	35	14.29	35	40	17.51
5	125	139.7	35	40	16.09	40	40	19.72
6	150	168.3	35	40	18.24	40	45	22.34
8	200	219.1	35	40	22.06	40	45	26.61
10	250	273.0	40	40	25.95	45	50	30.91

<i>Estimated Mean Temperature of Insulation:</i>	+50°C
<i>Ambient Air Temperature:</i>	+15°C
<i>Surface Emissivity ε (Outer Surface):</i>	0.05 / 0.9
<i>Assumed Thermal Conductivity (k-value) of Kooltherm™ 37kg/m³ Insulation:</i>	0.025 W/m·K

Table 2: Indicative Thickness (mm) of Insulation for Non-Domestic Hot Water (60°C) and Low Temperature Heating Service Areas (75°C) to Control Heat Loss.

(Based on NES Y50 Enhanced and Enhanced Capital Allowance thickness tables).

Recommended Thickness

Insulation Thickness Table to Control Heat Gain & Control Condensation

Steel Pipe Size			Water 0°C to 4.9°C			Water >4.9°C to <10°C			Water >10°C		
			max. heat gain			max. heat gain			max. heat gain		
NB (inches)	NB (mm)	OD (mm)	ε=0.05 silver	ε=0.9 black	(W/m)	ε=0.05 silver	ε=0.9 black	(W/m)	ε=0.05 silver	ε=0.9 black	(W/m)
3/8	10	17.2	25	20	3.47	20	15	2.97	15	15	2.48
1/2	15	21.3	25	20	3.81	20	15	3.27	15	15	2.72
3/4	20	26.9	25	20	4.18	20	20	3.58	15	15	3.05
1	25	33.7	30	20	4.60	25	20	4.01	20	15	3.41
1 1/4	32	42.4	30	25	5.11	25	20	4.53	20	15	3.86
1 1/2	40	48.3	30	25	5.45	25	20	4.82	20	20	4.11
2	50	60.3	35	25	6.17	25	25	5.48	20	20	4.78
2 1/2	65	76.1	35	30	6.70	30	25	6.30	20	20	5.51
3	80	88.9	40	30	7.77	30	25	6.90	20	20	6.17
4	100	114.3	40	30	9.15	35	25	8.31	25	20	7.28
5	125	139.7	45	30	10.45	35	25	9.49	25	20	8.52
6	150	168.3	45	30	11.86	35	25	10.97	25	20	9.89
8	200	219.1	50	35	14.61	40	30	13.57	30	20	12.27
10	250	273.0	50	35	17.48	40	30	16.28	30	25	14.74
12	300	323.9	55	35	17.48*	40	30	16.28*	30	25	14.74*
14	350	355.6	55	35	17.48*	45	30	16.28*	30	25	14.74*
16	400	406.4	55	35	17.48*	45	30	16.28*	30	25	14.74*
18	450	457.0	60	35	17.48*	45	30	16.28*	35	25	14.74*
20	500	508.0	60	35	17.48*	45	30	16.28*	35	25	14.74*
24	600	610.0	65	35	17.48*	50	30	16.28*	35	25	14.74*

Ambient Air Temperature:	+25°C
Relative Humidity:	80%
Surface Emissivity ε (Outer Surface):	0.05 / 0.9
Assumed Thermal Conductivity (k-value) of Kooltherm™ 37kg/m³ Insulation:	0.025 W/m·K

Table 3: Indicative Thickness (mm) of Insulation required for cold and chilled water supplies to control heat gain and control condensation.

*For pipes and vessels of diameter greater than 273mm, the items shall be assumed to be 273mm for calculation purposes.

(Based on Non-domestic Building Services Compliance Guide: 2013 Edition, Section 11; TIMSA HVAC Guide Sections 6.2.3 & 7.2; and BS 5422:2009, Tables 6, 8, 10 & 11).



Insulation Thickness Table to Protect Against Freezing

Steel Pipe Size				Pipe Location	
NB (inches)	NB (mm)	OD (mm)	ID (mm)	Indoor	Outdoor
½	15	21.3	16.0	30	75
¾	20	26.9	21.6	15	30
1	25	33.7	27.2	15	20
1¼	32	42.4	35.9	15	15
1½	40	48.3	41.8	15	15
2	50	60.3	53.0	15	15
2½	65	76.1	68.8	15	15
3	80	88.9	80.8	15	15

Copper Pipe Size			Pipe Location	
NB (mm)	ID (mm)		Indoor	Outdoor
15	13.6		35	130
22	20.2		15	30
28	26.2		15	20
35	32.6		15	15
42	39.6		15	15
54	51.6		15	15
76.1	73.1		15	15
108	105.0		15	15

<i>Ambient Air Temperature – Indoor:</i>	–6°C
<i>Ambient Air Temperature – Outdoor:</i>	–10°C
<i>Initial Water Temperature:</i>	+2°C
<i>Evaluation Period:</i>	12 hours
<i>Permitted Ice Formation:</i>	50%
<i>Assumed Thermal Conductivity (k-value) of Insulation:</i> Kooltherm™	0.025 W/m·K

Table 4: Minimum Thickness (mm) of Insulation required to give protection against freezing under specified commercial and institutional conditions.

(Based on BS 5422:2009 Table 29).

Kooltherm™ Insulated Pipe Support Inserts

Kooltherm™ Insulated Pipe Support Inserts are available to suit a full range of pipe diameters and in a full range of insulation thicknesses as shown in the following table; however, special sizes are available on request.

In addition to allowing a continuous vapour barrier on below ambient systems, thermal analysis of a +75°C LTHW system to EN ISO 10211:2007 has shown that Kooltherm™ Insulated Pipe Support System can limit heat loss by up to 4x more than rubber lined pipe clips, 5x more than metal pipe clips and 10x more than hardwood pipe support inserts.

Conventional Pipe Support Methods

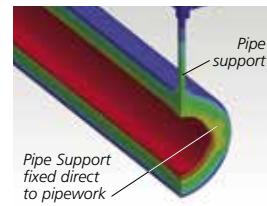

Rubber lined pipe support

Thermal analysis* illustrates heat loss of up to **4 x greater** than through the Kooltherm™ Insulated Pipe Support System.

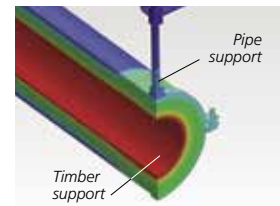

Timber support insert

Thermal analysis* illustrates significant heat loss of up to **10 x greater** than through the Kooltherm™ Insulated Pipe Support System.

**When analysed in accordance with BS EN ISO 10211: 2007*

Load bearing calculations for the standard range of Kooltherm™ Insulated Pipe Support Inserts are based upon the minimum compressive strength of the relevant density. They are designed to support the maximum static compressive loads imposed by horizontal water filled mild steel and copper pipework with hanger supports spaced at the maximum centres shown below. Kooltherm™ Insulated Pipe Support Inserts are not designed to accommodate pipe anchor loads and stresses.

Steel Pipe

Steel Pipe Size			Kooltherm™ Insulated Pipe Support Inserts				
NB (in)	NB (mm)	OD (mm)	Length (mm)	Max. Load (kg)	Spreader Plate (mm)	Support Distance (m)	Density (kg/m ³)
½	15	21.3	99	12	none	3	60
¾	20	26.9	99	15	none	3	60
1	25	33.7	99	19	none	3	60
1¼	32	42.4	99	23	none	3	60
1½	40	48.3	99	27	1.0	4	60
2	50	60.3	99	33	1.0	4	60
2½	65	76.1	99	62	1.0	4	80
3	80	88.9	99	73	1.0	4	80
4	100	114.3	99	94	1.0	4	80
5	125	139.7	99	115	1.0	6	80
6	150	168.3	124	410	1.5	6	120
8	200	219.1	124	534	1.5	6	120
10	250	273.0	124	666	1.5	6	120
12	300	323.9	200	1265	2.0	4	120
14	350	355.6	200	1389	2.0	4	120
16	400	406.4	200	1585	2.0	4	120
18	450	457.0	200	1784	2.0	4	120

Values given are based upon Kooltherm™ insulated pipe support inserts with an integral metal spreader plate where specified in the table above.



* Kooltherm™ Insulated Pipe Support Inserts are supplied with a self-adhesive lap. Kooltherm™ Pipe Insulation sections should be vapour sealed to the pipe support.

Copper Pipe

Copper Pipe Size		Kooltherm™ Insulated Pipe Support Inserts				Density (kg/m ³)
OD (mm)	Length (mm)	Max. Load (kg)	Spreader Plate (mm)	Support Distance (m)		
15	99	9	none	3	60	
22	99	12	none	3	60	
28	99	15	none	3	60	
35	99	19	none	3	60	
42	99	23	none	3	60	
54	99	30	1.0	4	60	
67	99	45	1.0	4	60	
76	99	62	1.0	4	80	

Values given are based upon Kooltherm™ insulated pipe support inserts with an integral metal spreader plate where specified in the table above.

Kooltherm™ FireSleeve

Kooltherm™ FireSleeves are a unique combination of high performance phenolic insulation, intumescent and stainless steel.

These innovative products act as a 2 hour fire stop to BS EN 1366, on both steel and copper pipe service penetrations through timber frame, metal stud and block wall applications, and incorporate the excellent fire and smoke performance of Kooltherm™ Pipe Insulation.

Kooltherm™ FireSleeves comprise of an outer sleeve of 0.5mm thick stainless steel which is clasp fastening and 205mm in length. It is lined with intumescent material. The stainless steel sleeve, encloses a 300mm length of Kooltherm™ Pipe Insulation which is also lined with intumescent material.

Contact Kingspan Industrial Insulation Ltd for further details of application.

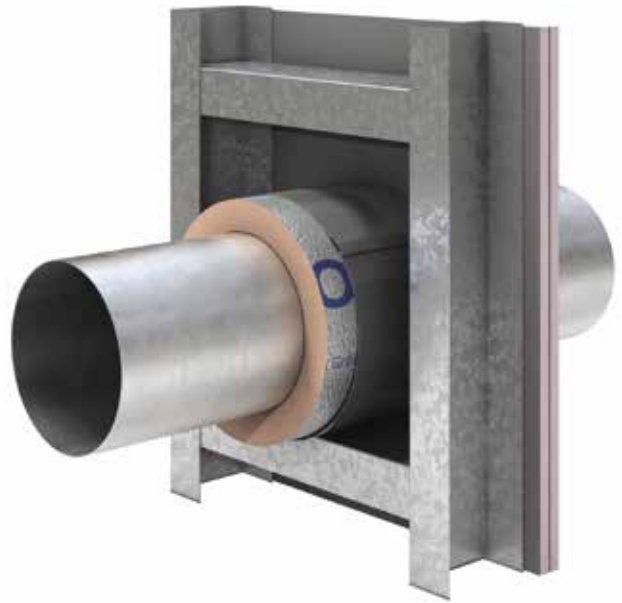
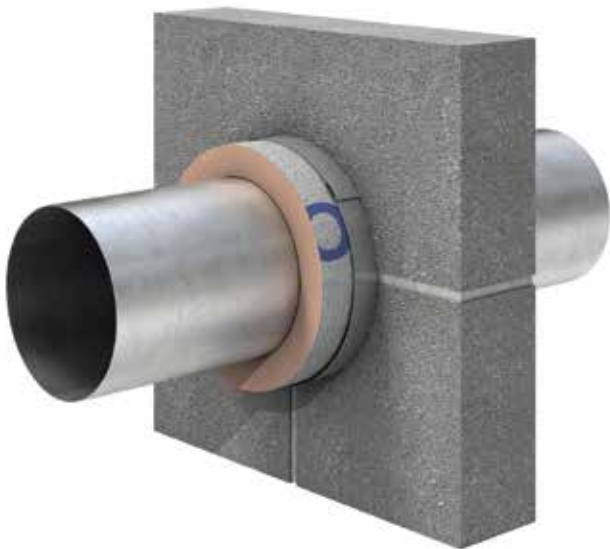
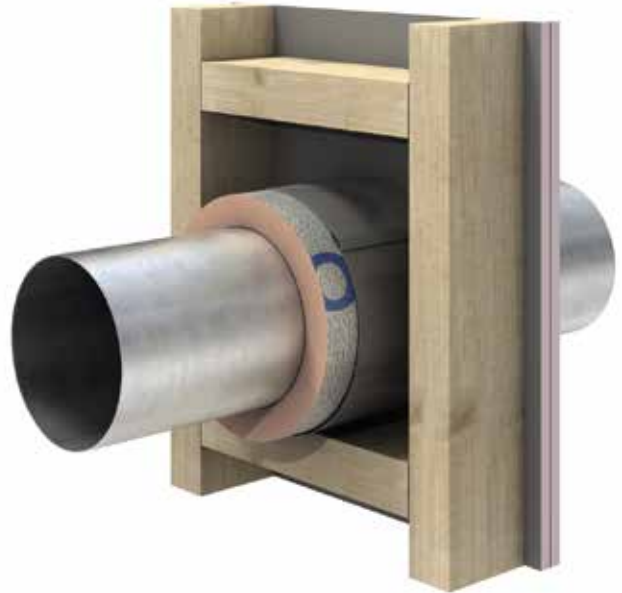

- Prepare opening in the wall, with minimal disturbance to surrounding structure.
- Open Kooltherm™ FireSleeve and install the 300mm lined Kooltherm™ Pipe Insulation onto the pipe. Fit the 205mm stainless steel fire sleeve over the intumescent lined Kooltherm™ Pipe Insulation and ensure that the stainless steel clasp is fully engaged.
- Ensure the Kooltherm™ FireSleeve is positioned centrally within the opening.

- Seal any gaps of 5mm or less around the exterior surface of the Kooltherm™ FireSleeve with a 2hr Fire Rated Intumescent Mastic.
- Large gaps over 5mm should be filled with an appropriate fire rated filler or mortar.
- Install Kooltherm™ Pipe Insulation flush to the Kooltherm™ FireSleeve and vapour seal in accordance with the project specification.

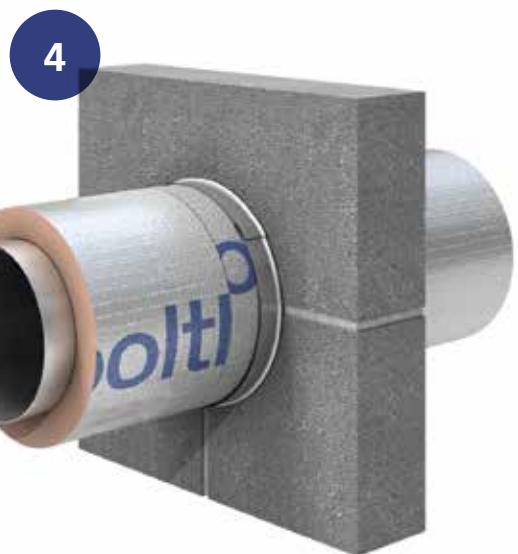
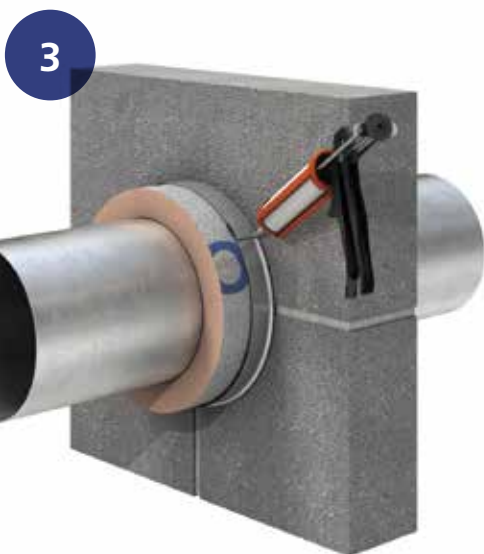
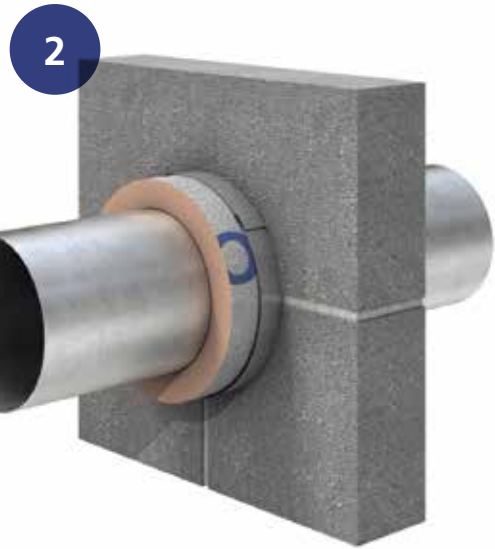

Technical Data

General Physical Properties (Kooltherm™ Insulation System)

Property	Test Method	Unit	Typical Value			
Nominal Density	(EN ISO 845) / (ASTM D 1622)	kg/m ³	37	60	80	120
Thermal Conductivity at +10°C	(EN 12667) / (ASTM C 518)	W/m·K	0.025	0.031	0.036	0.045
Colour			Pink	Grey	Grey	Grey
Closed Cell Content	(EN ISO 4590) Method 1 / (ASTM D 2856) Method B	%	≥ 90	–	–	–
Operating Temperature: Pipe Section	Upper Limit	°C	+110	+110	+110	+110
	Lower Limit	°C	-50	-50	-50	-50
Minimum Compressive Strength at +23°C	(EN 826) / (ASTM D 1621) Parallel	kPa	150	320	470	1000
	Perpendicular	kPa	100	170	340	800

General Physical Properties (Vapour Barrier Jacket)

Property	Test Method	Unit	Typical Value
Weight	(EN ISO 536)	g/m ²	100 + / – 30
Water Vapour Transmission	(ASTM F 1249)	g/m ² .24 hr	<0.1
	(ASTM E 96)		<0.02

Fire Test Classifications (Kooltherm™ Insulation)

Property	Test Method	Typical Result
Reaction to fire	EN 13501-1	B _L – s1, d0
Surface Burning Characteristics	ASTM E 84	Class A/1 (FSI 25/SD 50)
Fire propagation and flame spread		Class 0, in accordance with criteria set out in Approved Documents B for England & Wales
FM Approval	Class 4924	FM Approval per Approval Standard 4924



Kooltherm™ Pipe Insulation and Kooltherm™ Insulated Pipe Supports are CE Marked in accordance with BS EN 14314.



All Kingspan cardboard packaging uses 100% recycled content and is 100% recyclable.

BIM files are now available for free download from www.kingspanindustrialinsulation.com



Case Studies



Alder Hey Hospital



Kensington High Street



20 Fenchurch Street "Walkie Talkie"



RAL Space Centre



Birmingham Library



Marks & Spencer

Image supplied courtesy of DB Photography

Market Sectors

Marine

Terminal & LNG

Industrial

Hotel

Retail

Processing

Leisure



Infrastructure

Apartments

Commercial

Healthcare

Education



UK, Ireland & Gibraltar

Kingspan Industrial Insulation Ltd

Pembridge, Leominster, Herefordshire, HR6 9LA, United Kingdom

General Enquiries Tel: +44 (0) 1544 388 601

Technical Advice Tel: 0808 168 7363 or +44 (0) 1457 890534

Australasia, Oceania and SE Asia as far west and north as,
and including, Myanmar, China, Mongolia, Japan

Kingspan Insulation Pty Ltd

266 Beringarra Ave, Malaga, WA 6090, Australia

Tel: 1300 247 235 (for calls within Australia only)

Tel: +61 8 6240 6200 (for calls outside of Australia)

The rest of Europe (excluding Turkey, Malta & Cyprus)
and Russia

Kingspan Insulation N.V.

Visbeekstraat 24

B - 2300 Turnhout, Belgium

Tel: +32 14 44 25 25

Everywhere else excluding Canada, USA, Mexico, Bermuda,
the Cayman Islands, Puerto Rico & St Pierre and Miquelon

Kingspan Insulation LLC

P.O. Box 113826, Dubai Investment Park 2, Dubai, U.A.E.

Tel: +971 4 889 1000

www.kingspanindustrialinsulation.com



TM Kingspan, Kooltherm and the Lion Device are Trademarks of the Kingspan Group plc.

Kingspan reserves the right to amend product specifications without prior notice. All information, technical details and fixing instructions etc. included in this literature are given in good faith and apply to uses described. Recommendations for use should be verified as to the suitability and compliance with actual requirements, specifications and any applicable laws and regulations. For other applications or conditions of use, Kingspan offers a free Technical Advisory Service the advice of which should be sought for uses of Kingspan products that are not specifically described herein. Please check that your copy of the literature is current by contacting the Marketing Department.

Published November 2018